

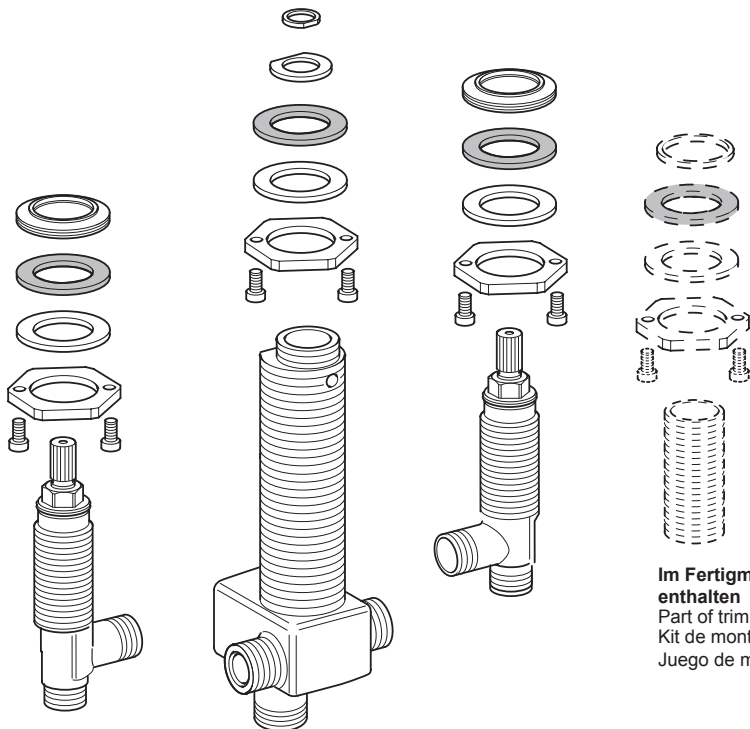

## ROUGH-IN KIT for HANSASTYLE; HANSACLASSIC

Montage- und Bedienungsanleitung • Mounting and operating instructions  
Instructions de montage et d'utilisation • Instruções de montagem y de uso



**Im Fertigmontageset  
enthalten**  
Part of trim kit  
Kit de montage final  
Juego de montaje final

**5870 0100 0017**

### Montageanleitung an Fliesenleger aushändigen!

Hand over the assembly instructions to the tiler!

Remettre les instructions de montage au carreleur!

¡Entregar las instrucciones de montaje al baldosador!



A020829/0908

### HANSA Metallwerke AG

P. O. BOX 81 02 40 • 70519 STUTTGART GERMANY  
SIGMARINGER STRASSE 107 • 70567 STUTTGART GERMANY  
PHONE: +49 711 1614 - 0 • FAX +49 711 1614 - 368  
info@hansa.de / www.hansa.com

### HANSA AMERICA Inc.

1770 Corporate Drive # 580  
Norcross, GA 30093  
PHONE: 678 334 2142 • FAX: 678 334 2148  
www.hansa.us.com

**HANSA Produkte sind ausschließlich durch einen sanitären Fachhandwerker zu montieren.**

HANSA products may only be installed by a licensed plumber.

Les produits HANSA doivent être montés exclusivement par un artisan spécialisé en sanitaires.

Los productos HANSA deben ser montados exclusivamente por un técnico especialista en instalaciones sanitarias

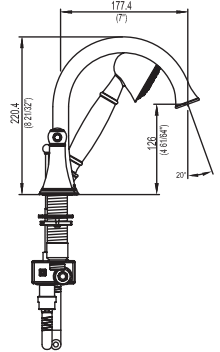
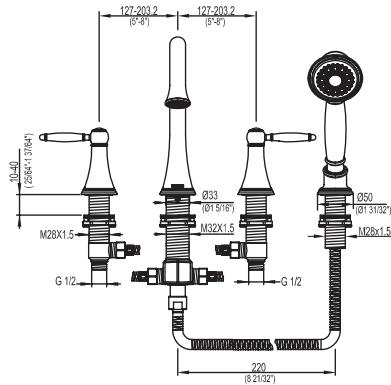

**5872 2011 XX17**

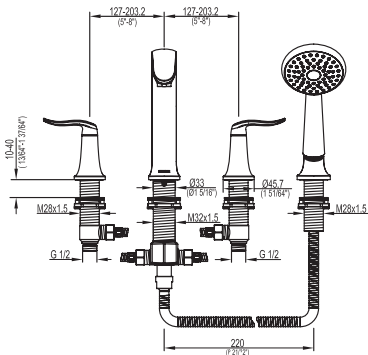

**5882 2011 XX17**

**Achtung!**

Attention!  
Attention!  
¡Atención!

**Bei Frostgefahr Hausanlage entleeren.**

Drain system completely if danger of frost.  
En cas de risque de gel, vidanger l'installation d'immeuble.  
En caso de peligro de hielo, purgar la instalación de agua, o bien vaciar las tuberías.

**Achtung!**

Attention!  
Attention!  
Atención!

**Vor Einbau der Armatur Rohrleitung gut spülen.**

Flush pipes completely before installing faucet.  
Avant la pose du mitigeur purger l'installation.  
Antes de colocar el monocomando limpiar la instalación.

**Achtung!**

Attention!  
Attention!  
Atención!

**Allgemein anerkannte Regeln der Technik sind einzuhalten.**

Please observe any recognized general technical rules.  
Prière de respecter les règles générales de la technique reconnues.  
Se tienen que observar las reglas generales reconocidas de la técnica.

**Achtung! Der Einbau einer Revisionsöffnung ist vorzusehen!**

Warning! There is space for the installation of an inspection opening!

Attention! Il faut prévoir le montage d'une ouverture de révision!

¡Atención! ¡Se tendrá que prever el montaje de una abertura de revisión!

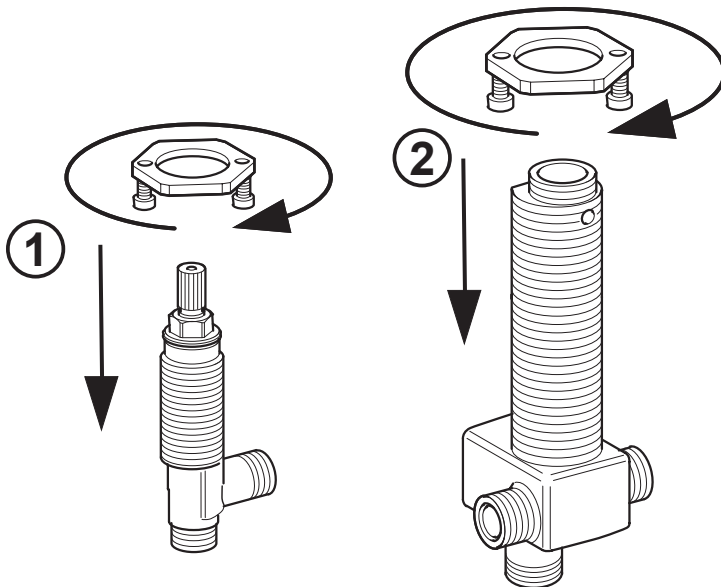
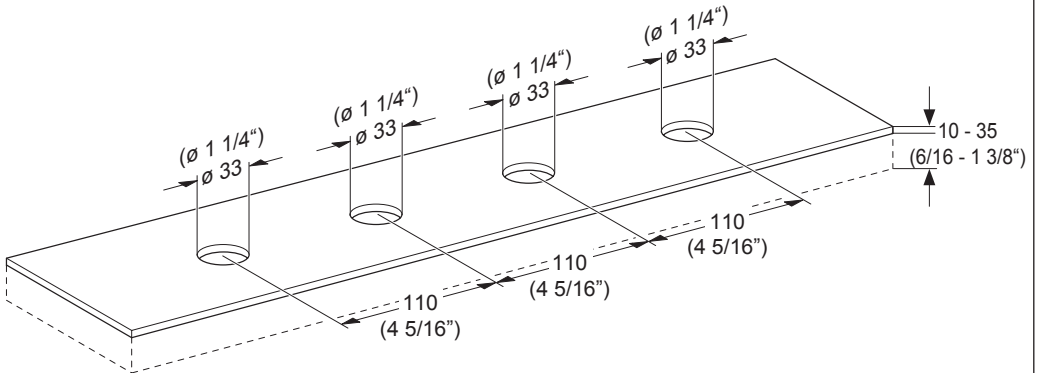

**Technische Änderungen vorbehalten**

Subject to technical alteration

Sous réserve de modifications techniques

Nos reservamos el derecho de efectuar modificaciones técnicas

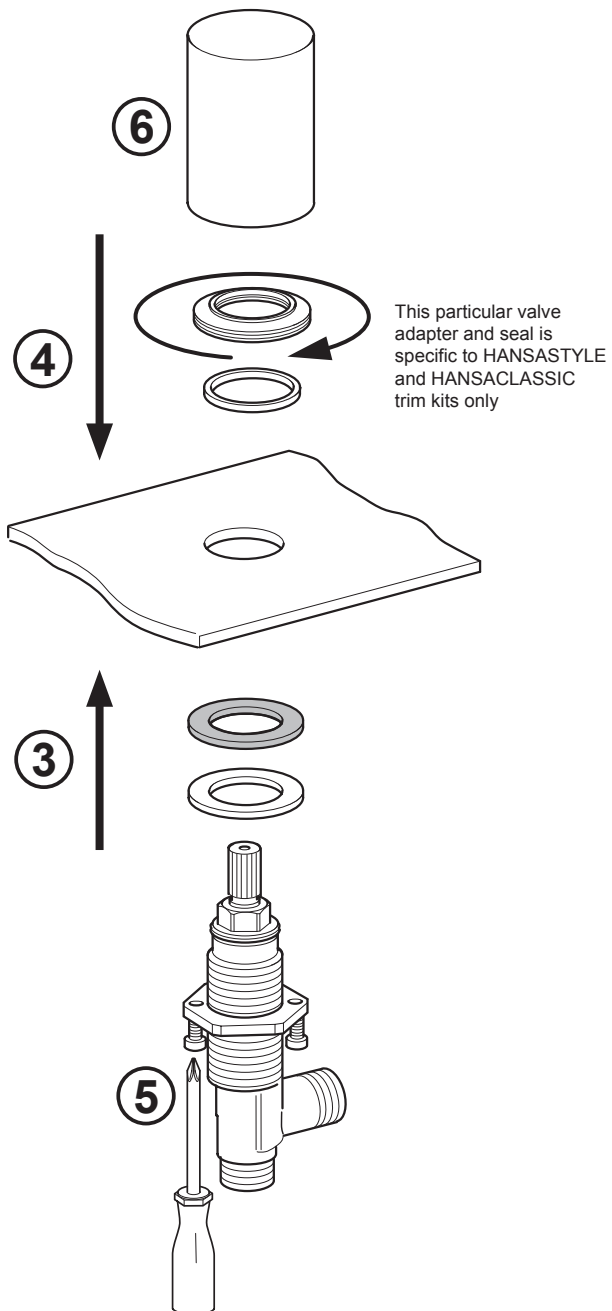
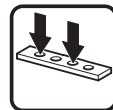

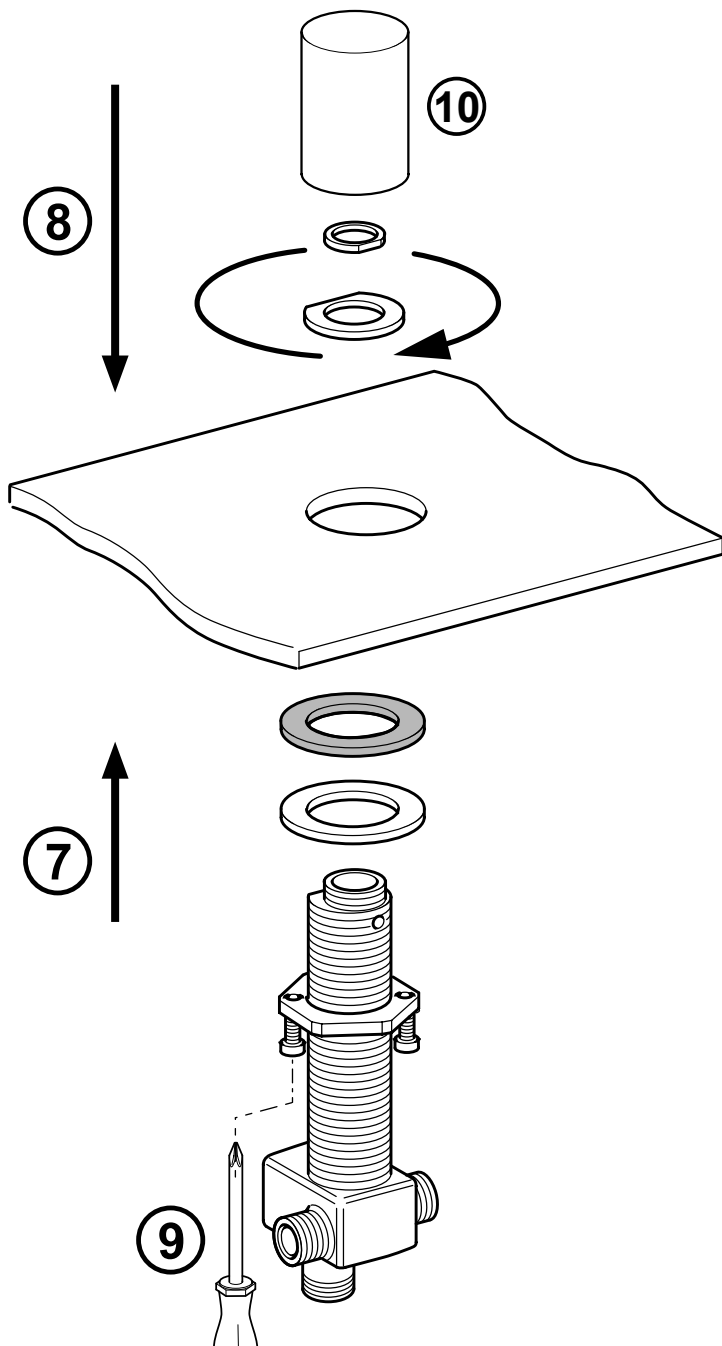

\* Handshower parts  
included in  
separate trim kit  
5872 2011 XX17 or 5882 2011 XX17

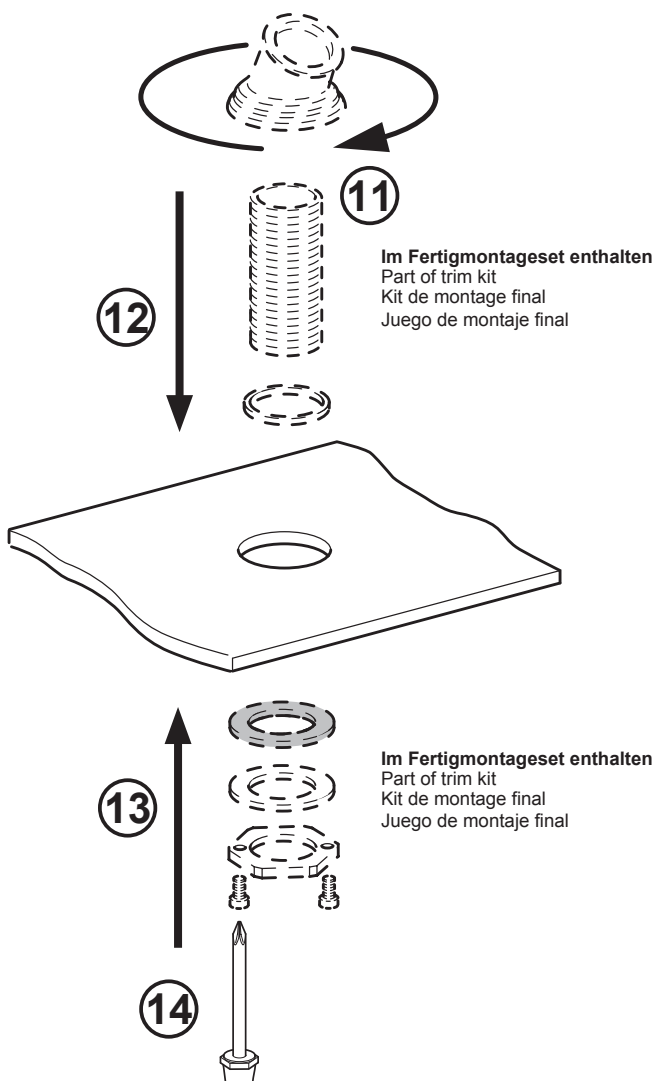
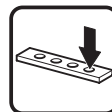

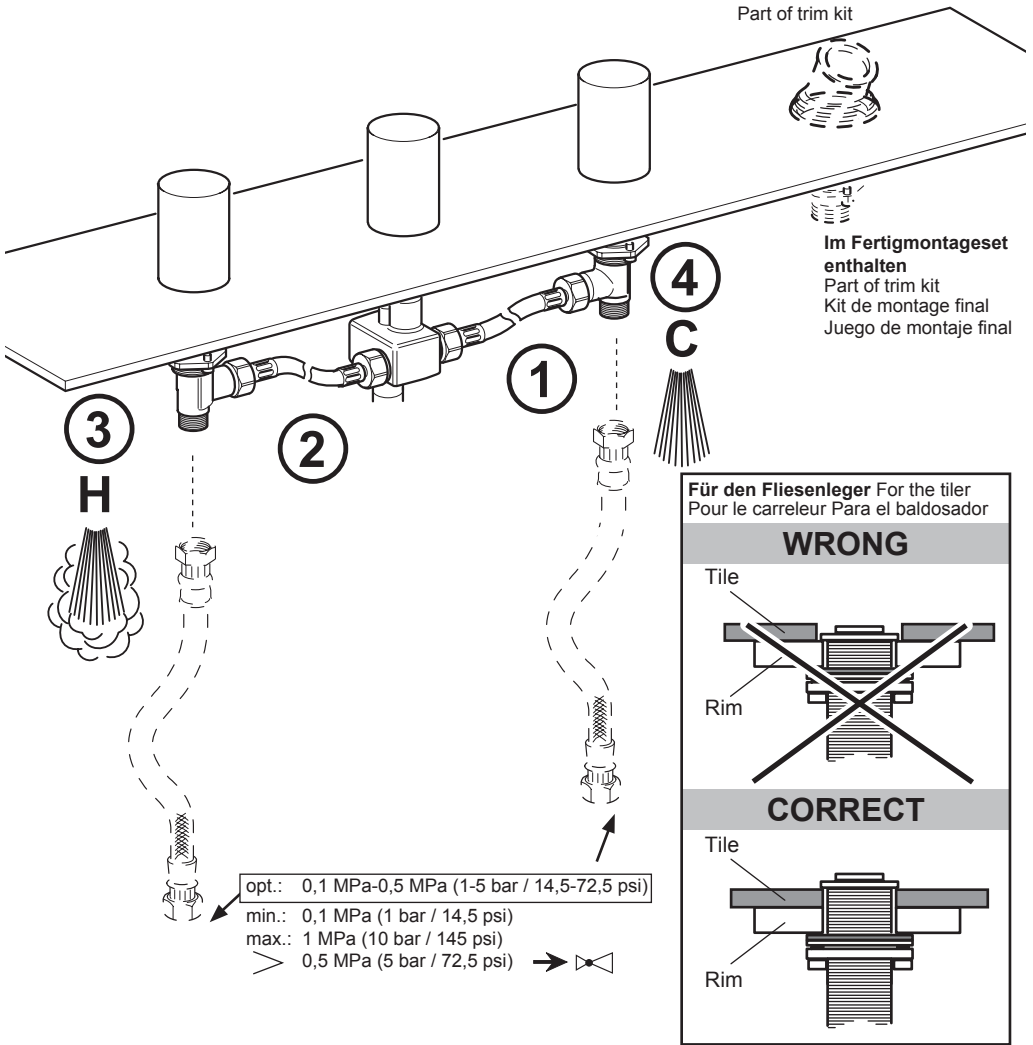

**Technische Daten • Technical details • Dates techniques • Datos técnicos**

**Heißwassertemperatur**  
Hot water temperature  
Température d'eau chaude  
Temperatura de agua caliente  
**max. 65 ° C**  
**max. 149 ° F**



**Literleistung**  
Flow rate  
Débits d'eau Portate  
Caudal de agua  
min. 9l/min @ 1.4 bar  
min. 2.4 gpm @ 20 psi  
max. 9.5l/min @ 5.5 bar  
max. 2.5 gpm @ 80 psi

**Prüfdruck**  
Testing pressure  
Pression d'épreuve  
Presión de prueba  
**max. 1,6 MPa**  
**(16 bar / 232 psi)**



## Pflegeanleitung für Hansa-Armaturen

Sehr geehrter Kunde,

mit dieser Hansa-Armatur haben Sie ein Qualitäts-Produkt erworben. Um die Schönheit der hochwertigen Oberfläche zu erhalten, sind folgende Hinweise zu beachten: Chrom, chrom-edelstahl und farbbeschichtete Oberflächen sind empfindlich gegen säure- und sandhaltige Reinigungsmittel sowie kratzende Schwämme.

**Achtung!**

Farbige Oberflächen erfordern eine besonders sorgfältige Behandlung bei Einbau und Benutzung. Farbabweichungen bei farbbeschichteten Oberflächen sind verfahrensbedingt.

**Pflege:**

Bei Verschmutzung oder Verkalkung, Armaturen mit Seifenwasser oder verdünntem Haushaltsessig reinigen, mit klarem Wasser nachspülen und trockenreiben. Farbige Oberflächen nicht mit alkoholhaltigen- oder Desinfektions-mitteln behandeln. Pflege wie oben. Schäden, die durch unsachgemäße Behandlung entstehen, unterliegen nicht der Hansa-Gewährleistung.



Care and maintenance instructions for Hansa faucets

Dear Customer,

You have purchased a high quality product, and to maintain its beautiful appearance for a long time to come, we suggest that you care for it as follows: Chrome, velvet chrome and color coated surfaces are sensitive to cleaning agents containing acids or abrasives as well as abrasive sponges. Important!

Color coated surfaces require extra care during installation and use. Slight color variations can occur with color coated faucets as a result of unavoidable process variations.

**Maintenance:**

Dirty and surface calcination are best removed with soapy water, followed by rinsing with plain water and drying. Avoid exposure of color coated surfaces to disinfectants or cleaning agents containing alcohol, and treat such surfaces as described above.

Careless treatment of faucets invalidates Hansa guarantee provisions.



Conseils d'entretien de notre robinetterie

Cher client,

avec cette robinetterie, vous avez acquis un produit de qualité, et afin de préserver la beauté de la surface, veuillez bien suivre nos conseils. Surfaces chromée, chromée-mat et traitements de couleur: Éviter les acides et les produits contenant du sable, ainsi que les éponges rugueuses.

**Attention!**

Les traitements en couleur demandent une manipulation très soignée au montage et lors de l'utilisation. Une légère différence de nuance est possible lors du traitement.

**Entretien:**

En cas de saïssure ou de dépôt de calcaire, nettoyer avec de l'eau savonneuse. Rincer avec de l'eau tiède et essuyer. Les pièces traitées ne doivent pas être nettoyées avec des produits contenant de l'alcool, ou des produits désinfectants. Entretien comme décrit ci-dessus.

Les dommages dus à une utilisation non conforme à ces conseils ne sont pas couverts par la garantie.



Consejos para el mantenimiento de nuestra grifería

Con esta grifería, Ud. ha adquirido un producto de calidad. Para conservar impecable su superficie, deberá seguir nuestras instrucciones:

Superficies cromada, cromada-mate y tratamiento de color: Evitar los ácidos y los productos que contienen arena, así como las esponjas ásperas.

**¡Atención!**

Los tratamientos en color requieren una manipulación muy cuidadosa en el montaje y en su empleo.

**Limpieza:**

En caso de suciedad o sedimento calcáreo, lavar con agua jabonosa. Enjuagar con agua tibia y secar. Las piezas en color no deben limpiarse con productos que contengan alcohol o acetona, ni con productos desinfectantes. Los daños o averías debidos a una utilización no conforme con estas instrucciones no están cubiertos por la garantía.

## WARRANTY ON KWC AND HANSA PRODUCTS

KWC AMERICA, INC. extends this warranty to original purchasers of its KWC and HANSA Brand products effective January 1, 1998.

The warranty is non-transferable.

KWC AMERICA, INC. will at its option repair, replace, or refund the original purchase price of any product that is determined to be defective in material or workmanship under conditions of normal and proper installation, usage, and maintenance during the warranty effectiveness periods specified below. All replaced products or parts shall be returned prepaid to KWC AMERICA, INC. in Norcross, Georgia.

This warranty does not cover installation, labor or any other incidental charges.

This warranty does not apply to products that have been altered in any way unless previously authorized in writing by KWC AMERICA, INC.

This warranty only applies to products purchased through authorized KWC AMERICA, INC. dealers and distributors.

Other malfunctions, damage, or conditions that void this warranty include but are not limited to those arising from use of products for purposes other than those intended by their design, faulty installation or maintenance, normal wear and tear, use of abrasive cleaning agents, abusive or negligent use of product, use of product in manner inconsistent with product instructions included with the product or on the KWC AMERICA, INC. websites ([www.kwc.us.com](http://www.kwc.us.com) and [www.hansa.us.com](http://www.hansa.us.com)), and effects of excessive water pressure or corrosion.

## WARRANTY EFFECTIVENESS

### RESIDENTIAL INSTALLATION

Except as otherwise specified in this paragraph all products installed in a private residence for normal private household use will carry a

LIMITED CONSUMER WARRANTY extending to the original purchaser of the product in the location where the product was originally installed.

Chateau fireclay sinks carry a 1 (one) year warranty from the original date of purchase.

Chrome and SPLENDURE™ products carry a LIMITED CONSUMER WARRANTY on the finish. Powder coated products carry

a 5 (five) year warranty on the finish. Faucets with LED lights carry a 5 (five) year warranty on the LED.

### COMMERCIAL/MARINE/OUTDOOR INSTALLATION

All products in a marine, commercial, or outdoor installation will be warranted by KWC AMERICA, INC. for a 1 (one) year period from the original date of purchase. Products or parts replaced during this period are warranted only for the period remaining in the initial 1 (one) year warranty.

### LIMITATIONS

This warranty is limited solely to the above statements, and this warranty and any warranties implied by state law will apply only for the periods herein specified. KWC AMERICA, INC. will not be held liable for any loss, damage or expense, incidental or consequential damages of any kind whether based on warranty, contract or negligence arising in the sale, use or repair of the product. Some states do not allow for the exclusion or limitation on how long an implied warranty lasts, so the above limitations or exclusions may not apply. This warranty gives you specific legal rights, and you may also have other rights which may vary from state to state. Unless otherwise contrary to state law governing the purchase, KWC AMERICA INC.'s liability will not exceed the list price for the product claimed to be defective or unsuitable.

To obtain warranty repair parts or replacement, simply write to:

KWC AMERICA

1770 Corporate Drive #580

Norcross, GA 30093

or contact us via our websites: [www.kwc.us.com](http://www.kwc.us.com) or [www.hansa.us.com](http://www.hansa.us.com)