

Universaleinbaukörper Set (Einzellösung) • Universal concealed unit set (individual solution)

Set universel de montage (modèle individuel) • Set universale di installazione (soluzione unica)

Universeelinbouwelement-set (afzonderlijke oplossing) • Universalt innbyggingslegemssett (enkeltløsning)

Set de montaje universal (Solución única) • Corpo de montagem universal, conjunto (solução individual)

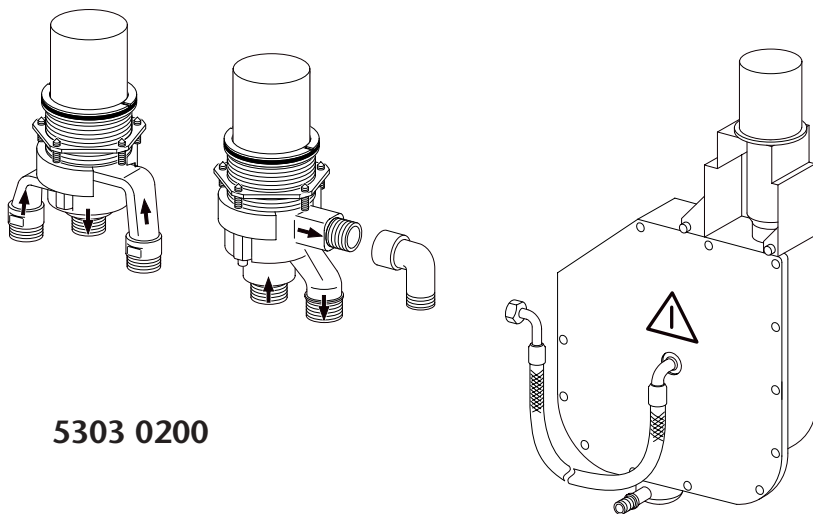

5303 0200

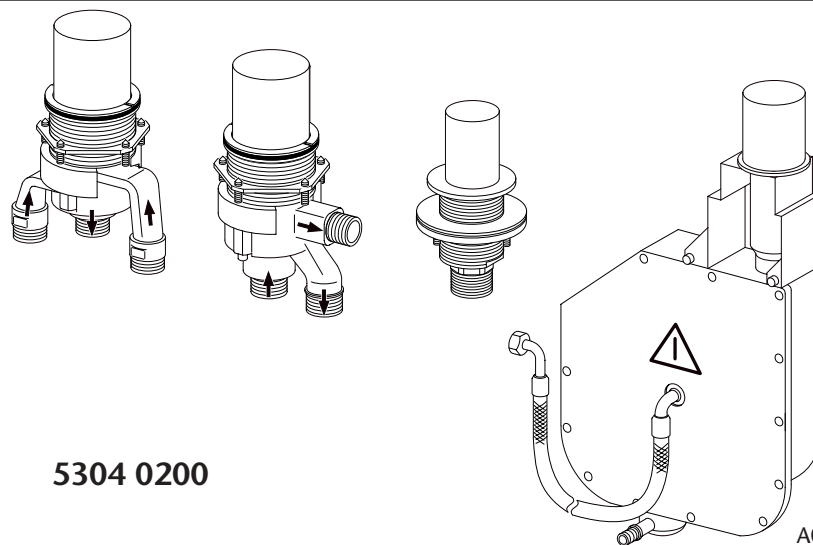

5304 0200

A015281/0109

Montage- und Bedienungsanleitung

Mounting- and operating instructions • Instructions de montage et d'utilisation

Istruzioni di montaggio e d'uso • Montage- en bedieningshandleiding • Montasje- og betjeninganvisning

Instrucciones de montaje y de uso • Instruções de montagem e de uso

Zur Einhaltung der Geräuschwerte nach DIN 4109 sind bei höheren Drücken als 6 bar Druckminderer in die Hauptleitung einzubauen

In order to keep noise level DIN 4109 it is recommended to install pressure reducing valves in case supply pressure is higher than 6 bars.

Pour respecter les valeurs de bruit selon la DIN 4109 des réducteurs de pression sont à installer quand la pression de service dépasse 6 bars.

Per mantenere i valori di rumorosità secondo norme DIN 4109 con pressioni superiori a 6 bar si deve montare un riduttore di pressione sulla tubazione principale.

Om de geruiswaarden volgens DIN 4109 aan te houden moet, indien de druk hoger is dan 6 bar, endrukreducer-ventiel ingebouwd worden.

For å holde de lydtempede verdier etter DIN 4109 må reduksjonsventil monteres på hovedledningen ved høyere trykk enn 6 bar.

Para respetar los niveles de ruido según la norma DIN 4109, debe instalarse un reductor de presión cuando la presión de servicio es superior a 6 bars.

Para respetar os níveis de ruído segundo a norma DIN 4109, deve instalar-se um redutor de pressão, quando a pressão de serviço é superior a 6 bars.

Achtung! Bei Frostgefahr Hausanlage entleeren

Attention! Drain system completely if danger of frost.

Attention! En cas de risque de gel, vidanger l'installation d'immeuble.

Attenzione! In caso di pericolo di gelo, svuotare l'impianto

Attentie! Bij vorstgevaar waterleiding aftappen

OBS! Ved frostfare tømme husanlegget.

¡Atención! En caso de peligro de hielo, purgar la instalación de agua ,o bien vaciar las tuberías.

Atenção! Em caso de perigo de gelo esvaziar os tubos.

Betriebsbedingungen / Operation conditions / Conditions de fonctionnement / Condiciones de funcionamiento
 Condizioni di esercizio / Funktie-eisen / Driiftsbetigesler / Condições de funcionamento

Prüfdruck

Testing Pressure
 Pression d'épreuve
 Pressione di prova
 Testdruk
 Prøvetrykk
 Presión de prueba
 Pressão de prova

max: 1,6 MPa (16 bar/232 psi)

Fließdruck empfohlen

Recommended flow pressure
 Pression d'alimentation recommandée
 Pressione dinamica raccomandata
 Aanbevolen waterdruk
 Anbefalt trykk
 Presión de alimenta cion recomendada
 Pressão de alimentação recomendada

1 - 5 bar

Betriebsdruck

Flow pressure
 Pression de service
 Pression d'esercizio
 Werkdruk
 Arbeidstrykk
 Presión de servicio
 Pressão de serviço

max: 10 bar

Heißwassertemperatur

Hot water temperature
 Température d'eau chaude
 Temperatura acqua calda
 Warm water temperatuur
 Varmtvannstemperatur
 Temperatura de agua caliente
 Temperatura da água quente

max: 90 °C

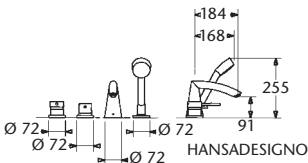

Einbaumaße

Installation dimensions
 Dimensions d'encastrement
 Dimensioni d'ingombro

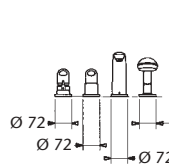

Inbouwmaten

Byggemål
 Dimensiones de instalación
 Dimensões de instalação

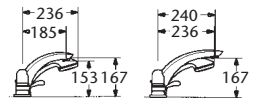

Variante: HANSALUX

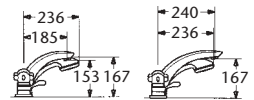
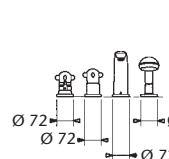

Variante: HANSALUXSTYLE

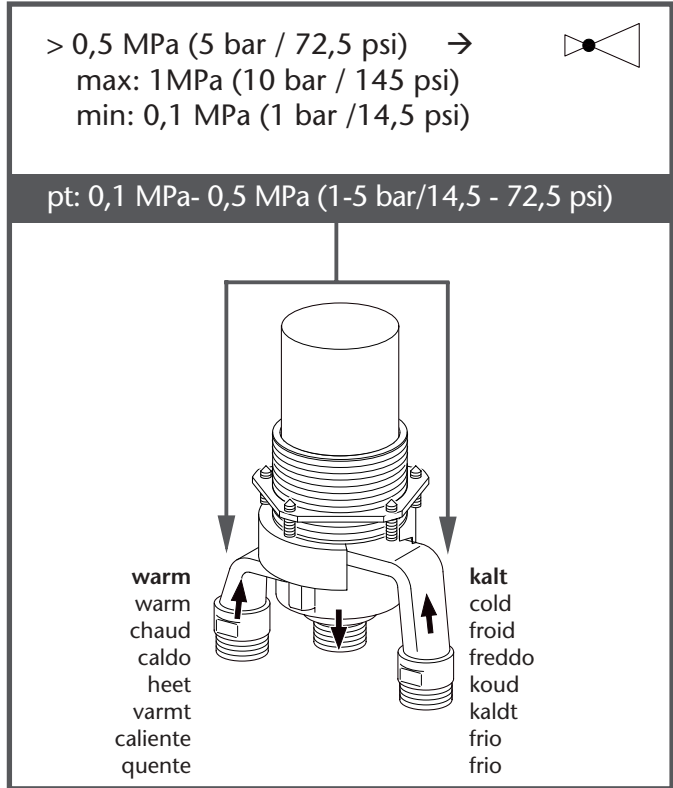

max. 30 mm

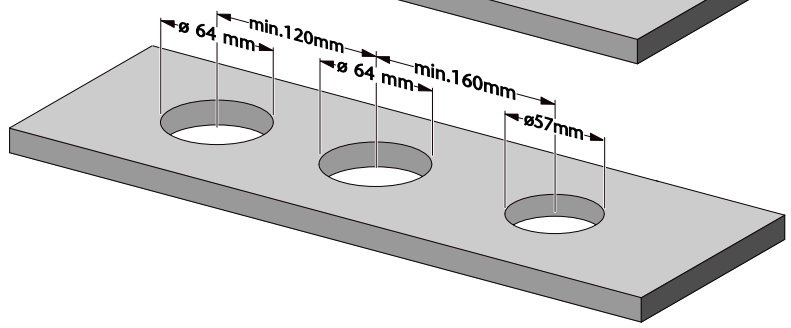
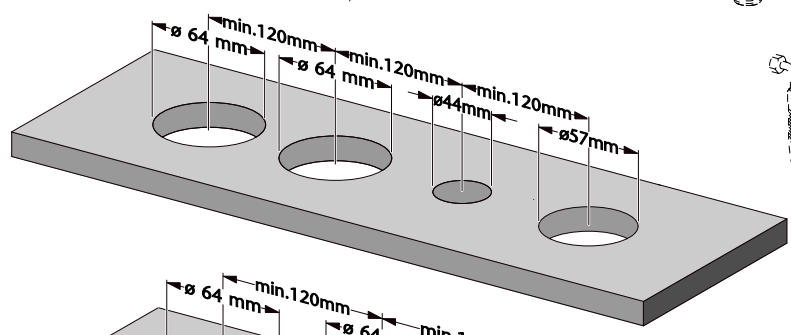
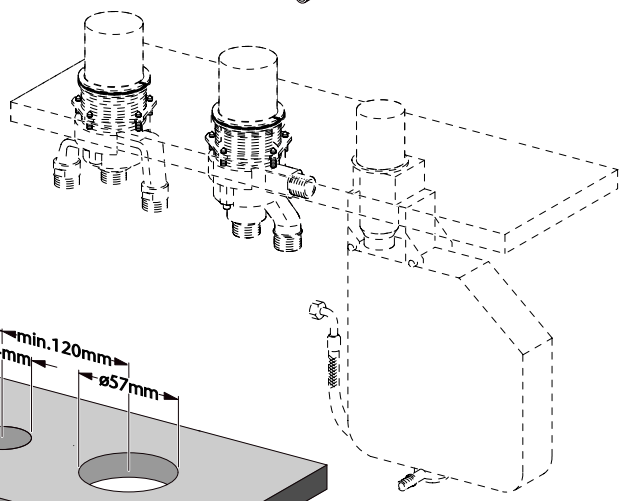
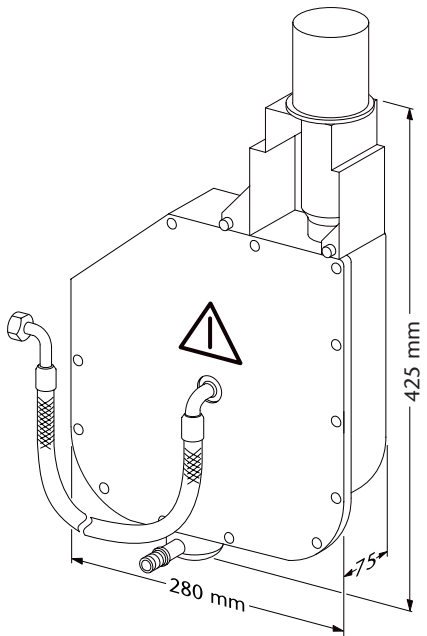
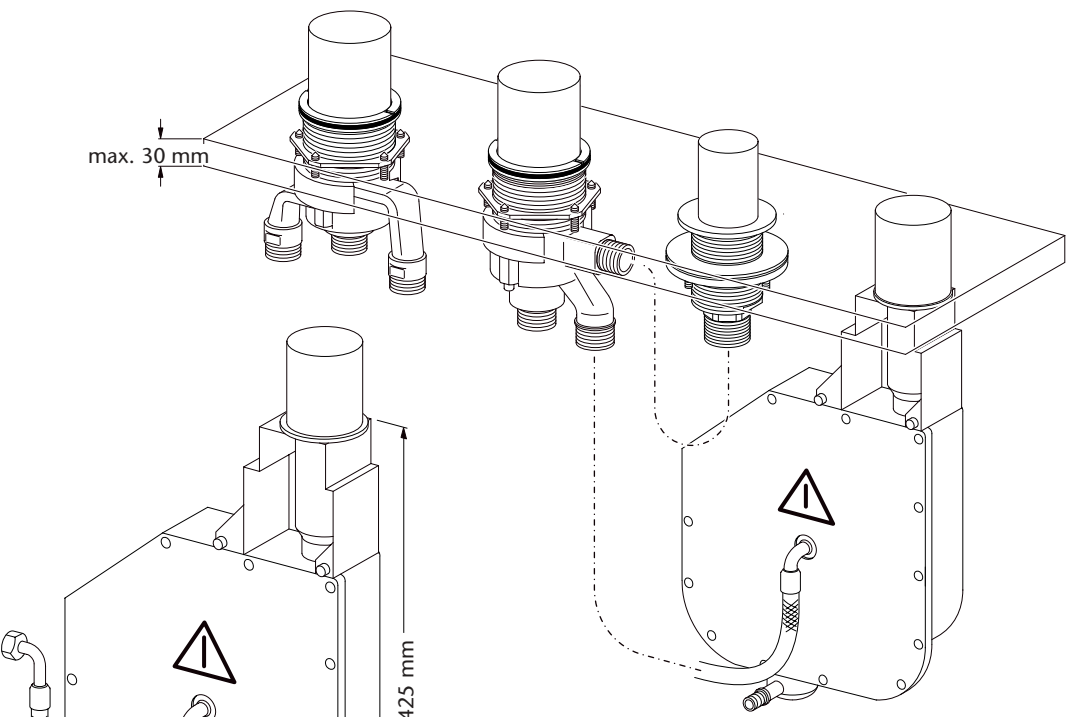

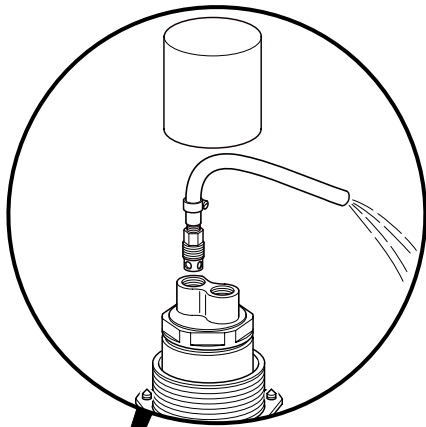

Achtung!
Vor Einbau der Armatur Rohrleitung gut spülen

Attention!
Flush pipes well before installing mixer

Attention!
Avant la pose du mitigeur purger l'installation

Attenzione!
Prima di installare il miscelatore spurgare bene le condutture

Attentie!
Voor het inbouwen van de kraan, waterleiding goed doorspoelen

OBS!
Gjennomspyl rørledningene godt før montering av armaturen

jAtencion!
Antes de colocar el monocomando limpiar la instalación

Atenção!
Antes de colocar o monocomando, limpar a instalação

warm
warm
chaud
caldo
heet
varmt
caliente
quente

kalt
cold
froid
freddo
koud
kaldt
frio
frio

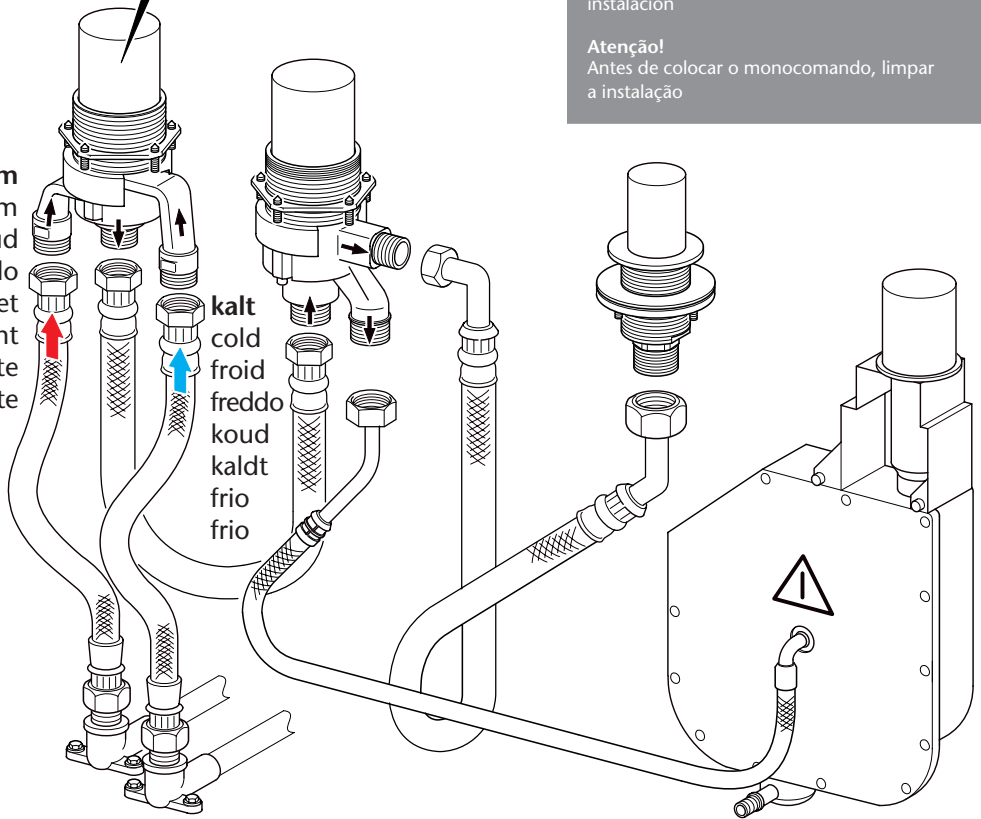

Technische Änderungen vorbehalten

Subject to technical alteration

Sous réserve de modifications techniques

Salvo cambiamenti tecnici

Technische wijzigingen voorbehouden

Forbehold om tekniske endringer

Nos reservamos el derecho de efectuar modificaciones técnicas

Sujeito a alterações técnicas

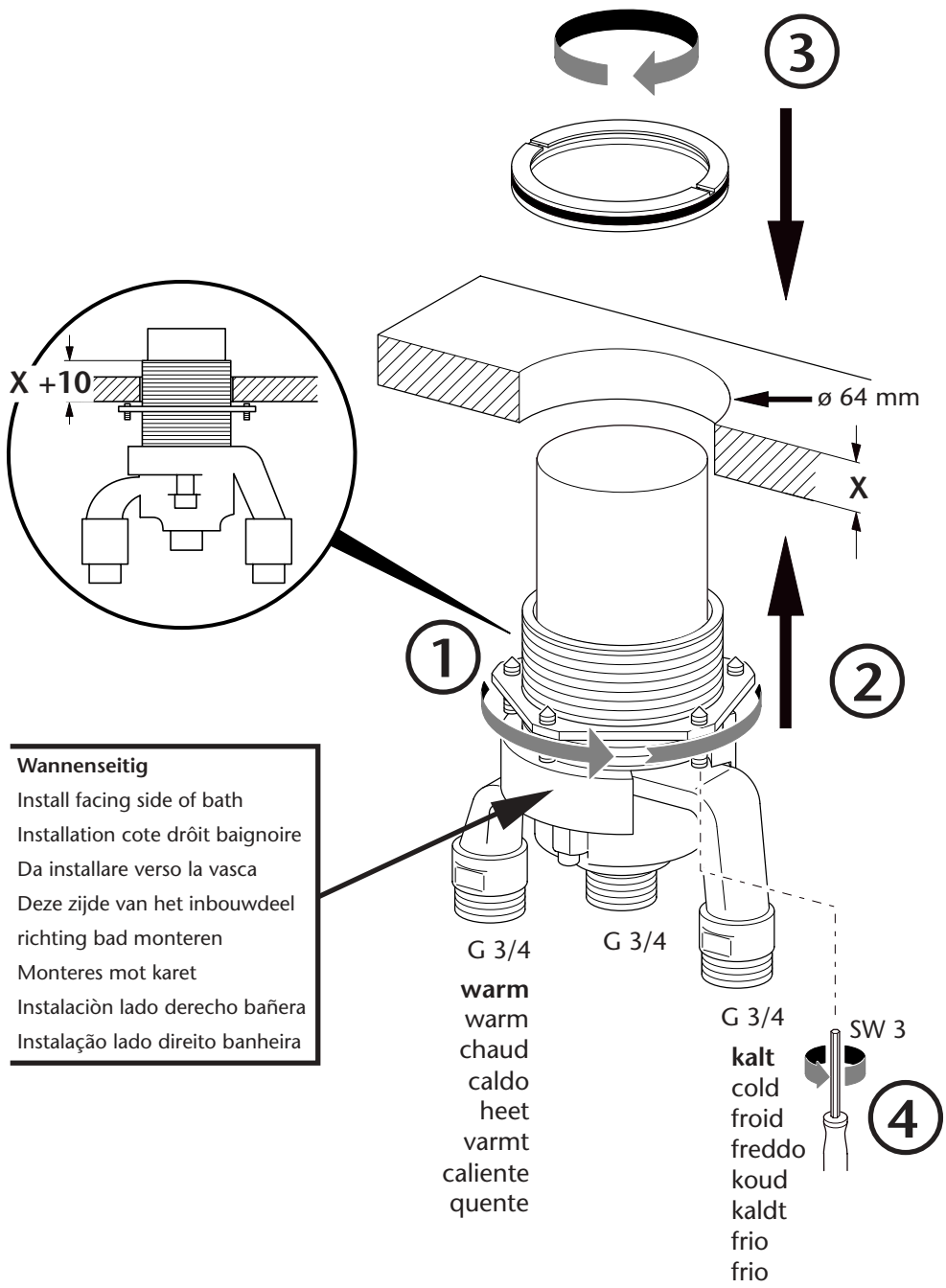

Wannenseitig
Install facing side of bath
Installation cote drôit baignoire
Da installare verso la vasca
Deze zijde van het inbouwdeel
richting bad monteren
Monteres mot karet
Instalaciòn lado derecho bañera
Instalação lado direito banheira

Montage Umstellung
Diverter installation
Modification de montage
Adattamento del montaggio

Montage omzetting
Montering omstilling
Montaje del cambio
Montagem unidade de mudança

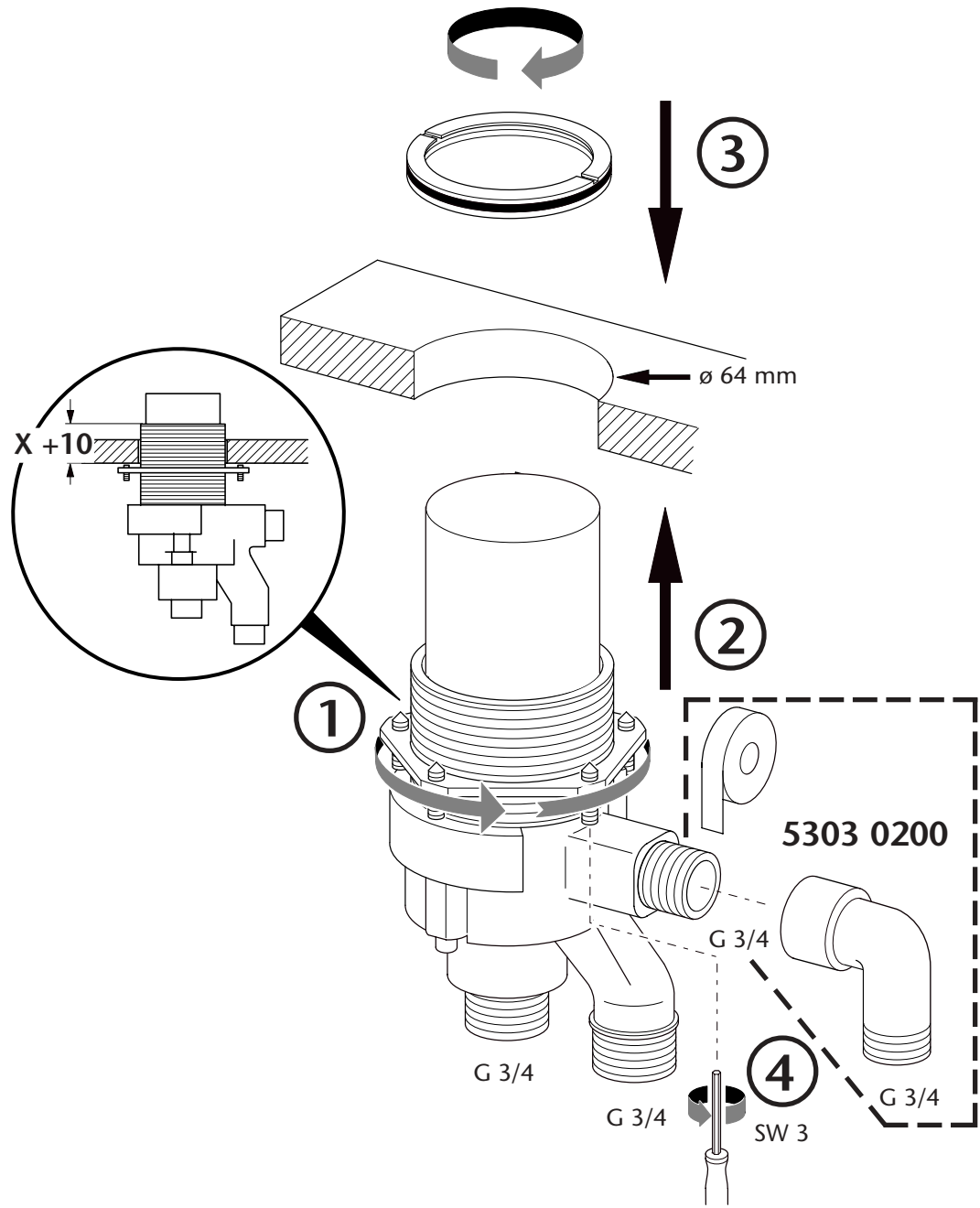

Montage Auslaufgehäuse
Run-off housing installation
Montage boîtier de vidange
Montaggio della cassetta di scarico

Montage uitloopbehuizing
Montering avløpskapsel
Montaje del carter de salida de agua
Montagem caixa de descarga

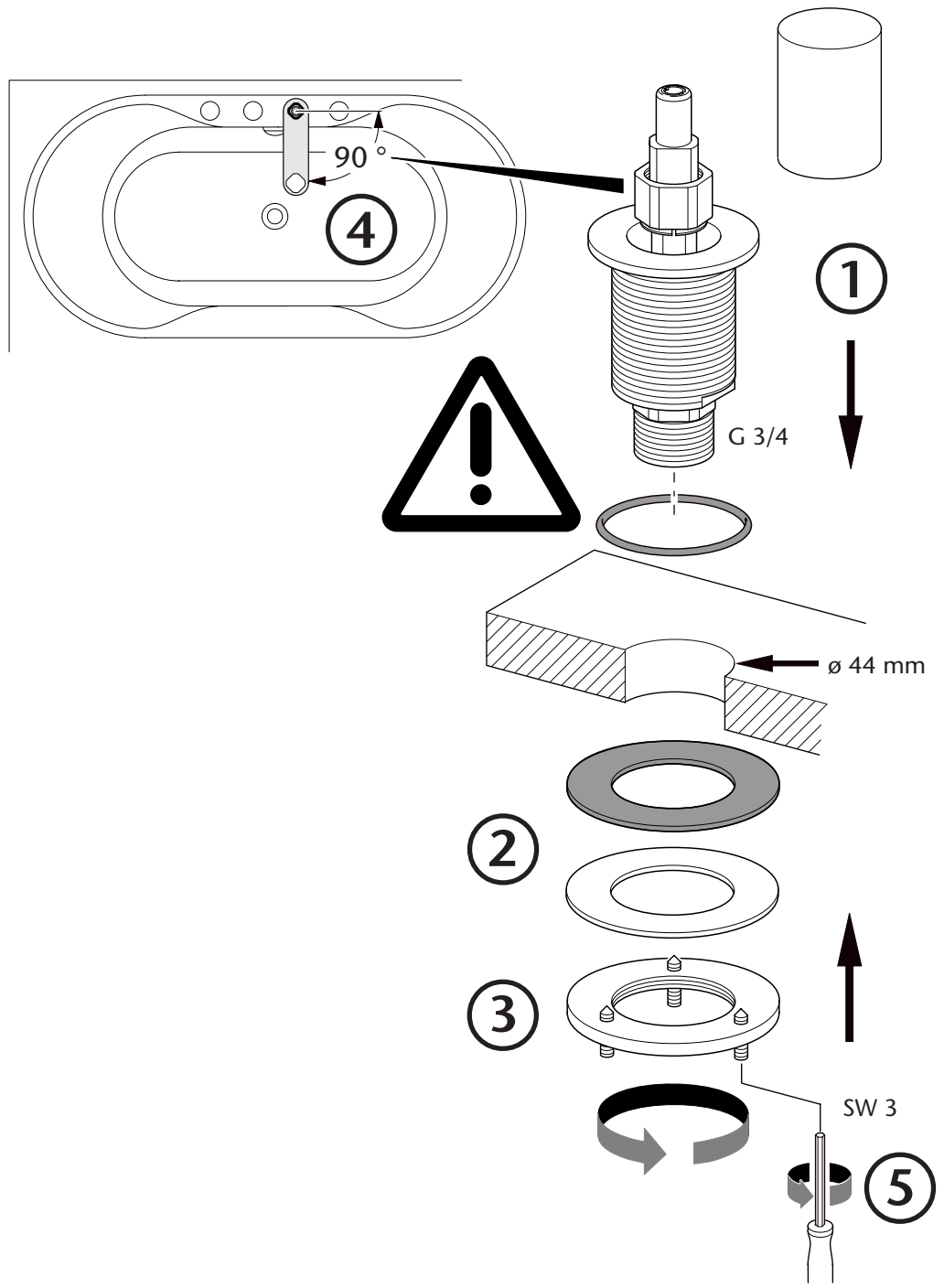

Montage Schlauchaufroller

Hose reel installation

Montage enrouleur de tuyau

Montaggio dell'avvolgitore del tubo

Montage slangoproller

Montering slangetrommel

Montaje para enrollar la manguera

Montagem enrolador de mangueira

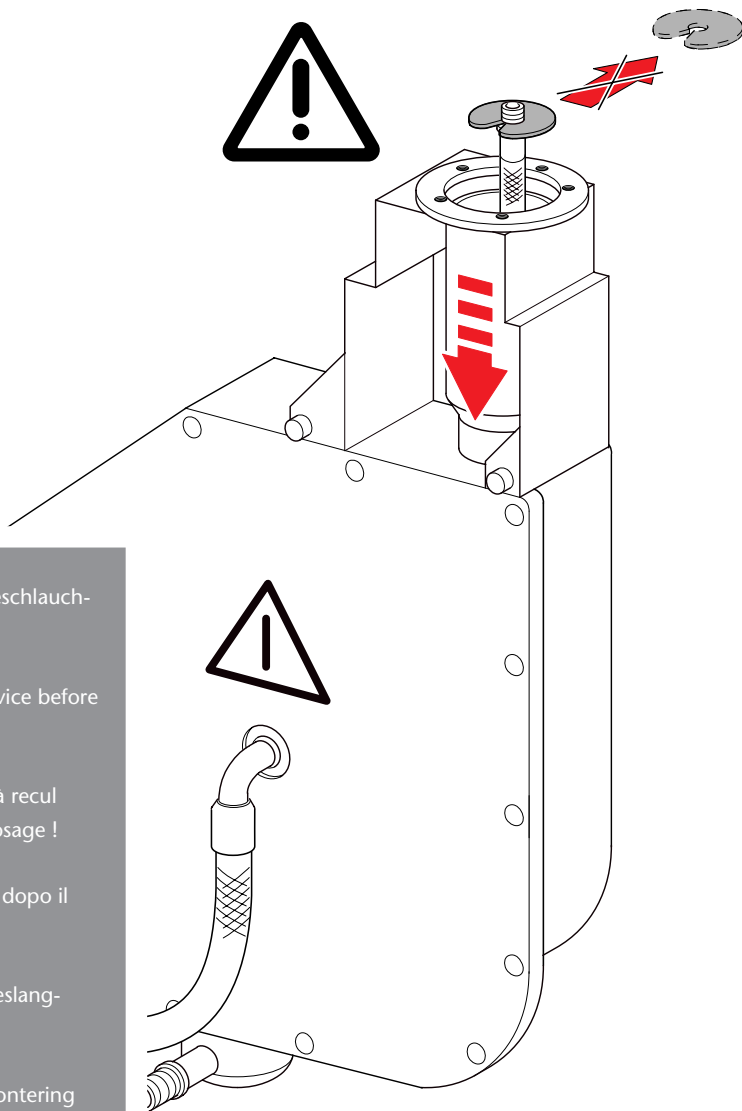

Achtung!

Rückfallsicherung erst nach Brauseschlauchmontage entfernen !

Attention!

Do not remove the non-return device before connecting the shower hose!

Attention!

Ne retirer le dispositif de sécurité à recul qu'après montage du tuyau d'arrosage !

Attenzione!

Togliere la valvola di ricaduta solo dopo il montaggio del tubo della doccia !

Attentíe!

Terugvalbeveiliging pas na doucheslangmontage verwijderen!

OBS!

Løsesikringen fjernes først etter monteringen av dusjslangen !

¡Atención!

¡ Quitar el sistema de seguridad anti-retorno solamente tras la instalación de la manguera !

Atenção!

Retire a proteção contra queda só após montar a mangueira de chuveiro!

Montage Schlauchaufroller
Hose reel installation
Montage enrouleur de tuyau
Montaggio dell'avvolgitore del tubo

Montage slangoproller
Montering slangetrommel
Montaje para enrollar la manguera
Montagem enrolador de mangueira

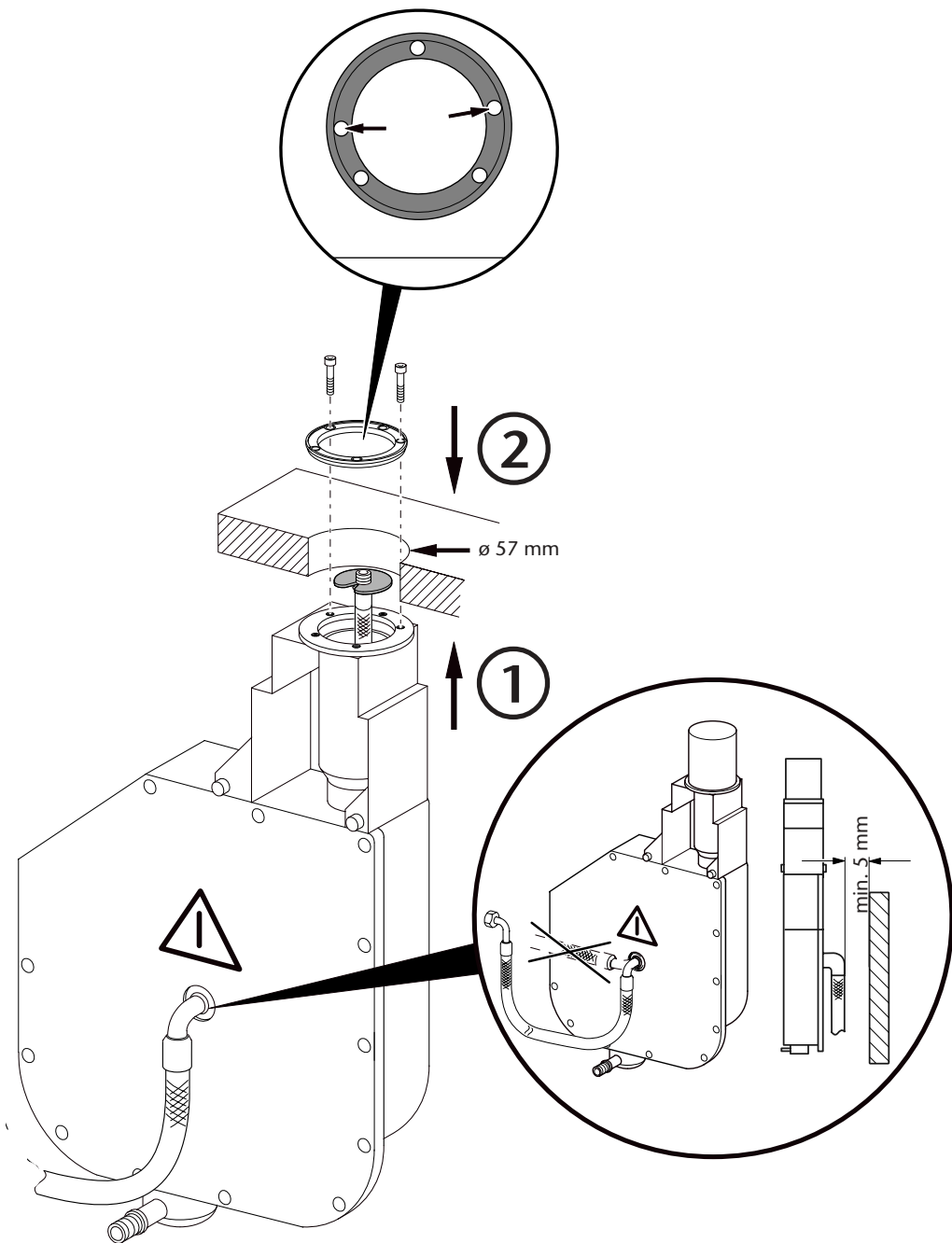

Schlauchkasten-Entwässerung

Hose box drainage

Boîtier tuyau de vidange

Scarico della cassetta del tubo

Slangenkast-ontwatering

Tørrelgging av slangekassen

Armario de mangueira - vacio

Caixa de mangueira – esgoto

5304

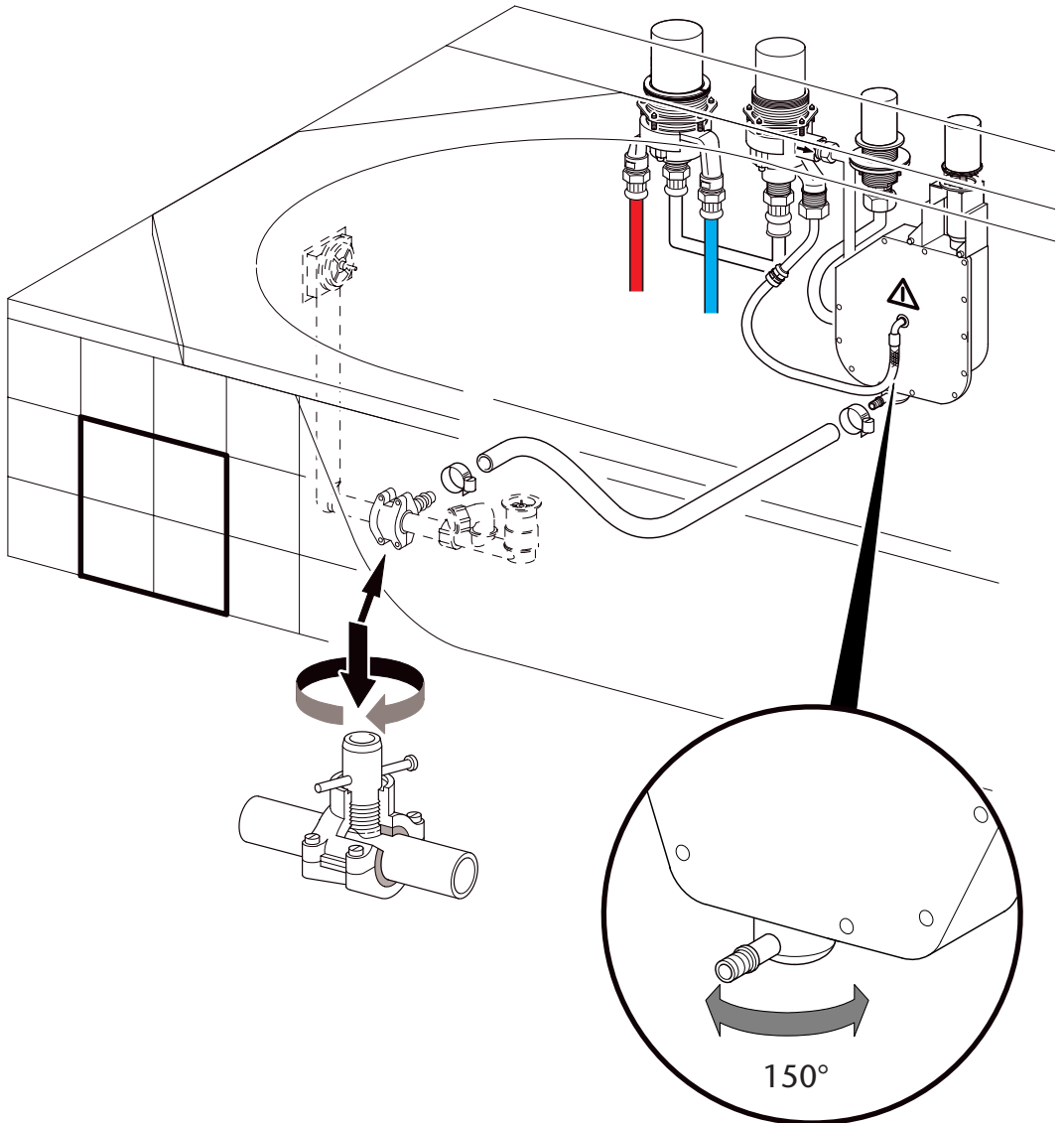

Schlauchkasten-Entwässerung

Hose box drainage

Boîtier tuyau de vidange

Scarico della cassetta del tubo

Slangenkast-ontwatering

Tørrelgging av slangekassen

Armario de manguera - vacío

Caixa de mangueira - esgoto

5303

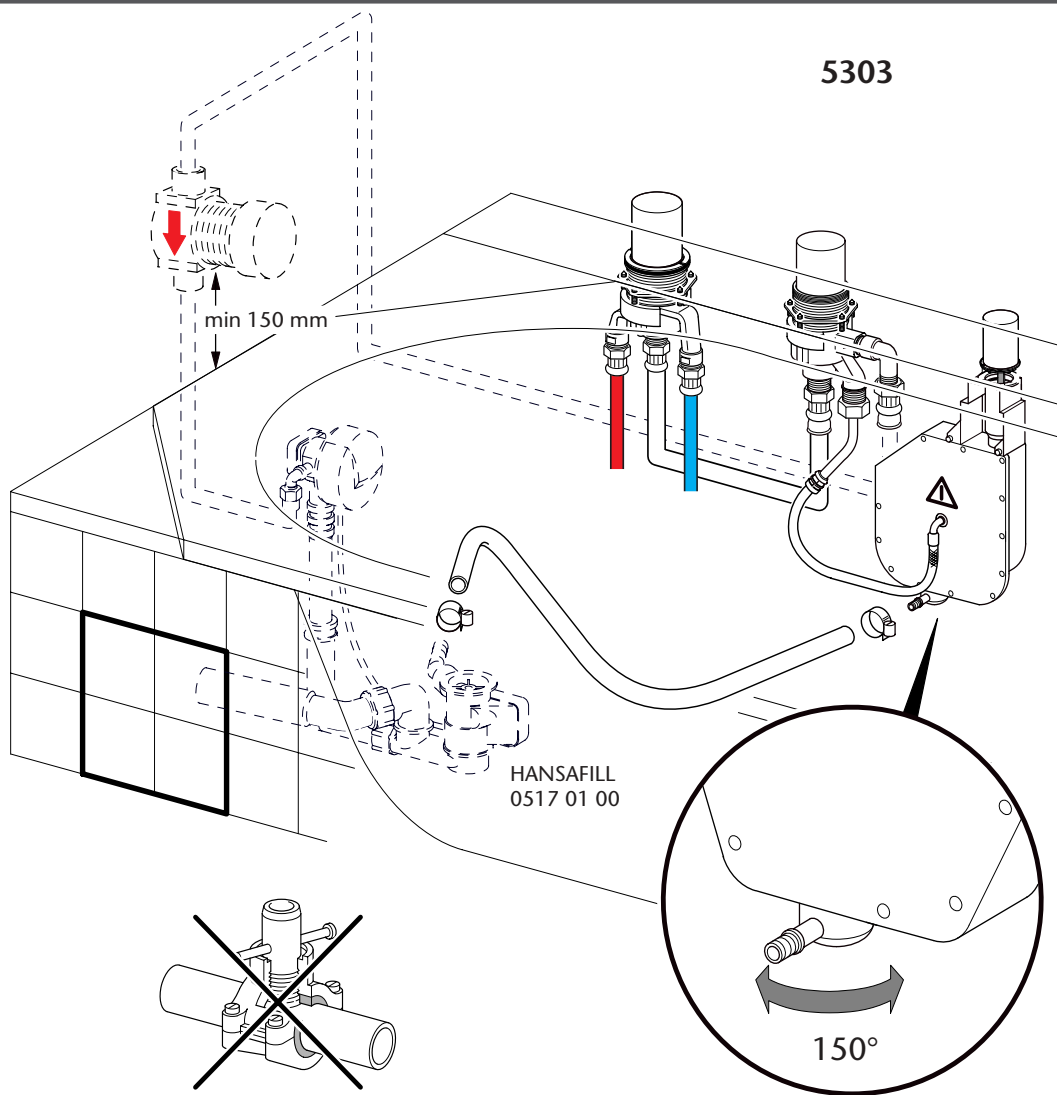

HANSA METALLWERKE AG

P. O. BOX 81 02 40 • D-70519 STUTTGART
SIGMARINGER STRASSE 107 • D-70567 STUTTGART

Tel.: +49-711 16 14 - 0 • FAX +49-711 16 14 - 368

E-mail: info@hansametall.com • Internet: www.hansametall.com